

PalArch's Journal of Archaeology of Egypt / Egyptology

SCORING INSTRUMENT DEVELOPMENT OF CHARACTER EDUCATION BASED ON LOCAL CULTURE FOR ELEMENTARY SCHOOL STUDENTS

Sukadari^{1}, Eko Wahyunanto Prihono², Juang Kurniawan Syahrurah³, Mohamad Maulana
Magiman⁴, Gulzhaina K. Kassymova^{5,6,7}*

^{1,3} Universitas PGRI Yogyakarta, Indonesia,

² State Islamic Institute of Ambon, Indonesia ²,

⁴ Department of Social Science, Faculty of Agriculture and Food Science,
Universiti Putra Malaysia, Bintulu Campus, Sarawak, Malaysia

⁵ Abai Kazakh National Pedagogical University, Kazakhstan⁵

⁶ Institute of Metallurgy and Ore Beneficiation, Kazakhstan⁶

⁷ Satbayev University, Almaty, Kazakhstan⁷

¹ sukadariupy@gmail.com

**Sukadar, Eko Wahyunanto Prihono, Juang Kurniawan Syahrurah, Mohamad Maulana
Magiman, Gulzhaina K. Kassymova. Scoring Instrument Development Of Character
Education Based On Local Culture For Elementary School Students-- Palarch's Journal
Of Archarology Of Egypt/Egyptogy 17(3), 12-24. Issn 1567-214x**

Keywords: Assessment, Character Education, Local Culture, Efa, Cfa

ABSTRACT

This study aims to produce instruments that meet the requirements to measure the characters consisting of caring, polite, honest, disciplined attitude for fifth grade students of elementary schools in Yogyakarta. The approach used in this research is Research and Development with the Plomp model combined with the steps of developing the Djemari Mardapi instrument. Instrument of character education assessment has been declared valid and reliable. The content validity was tested through experts and Aiken's index was obtained for each item ≥ 0.60 so that the validity coefficient was accepted and considered to be reasonable and it could be said that the instrument was valid in content. The construct validity was carried out by exploratory factor analysis (EFA) and confirmatory factor analysis (CFA). The results of the exploratory factor

analysis showed the KMO value of 0.926 with Sig Bartlett's Test of 0.000. Confirmatory factor analysis shows the Chi-Square value of 0.024; RMSEA = 0.020; GFI = 0.98; SRMR = 0.021; AGFI = 0.97; CFI = 0.99; and RFI = 0.97. Cronbach's Alpha reliability estimates are 0.869. The results show that: 1) the instrument can be used because it has been substantially fulfilled, construction and language aspects based on the results of the Aiken's V validity test and 2) the results of the validity testing in confirmatory factor analysis show that all items in the local culture-based character education assessment instrument can be used to assess the character of fifth grade elementary school students in Yogyakarta.

INTRODUCTION

Law No.20 of 2003 concerning the National Education System Article 3 states that the National Education functions to develop capabilities and shape the character and civilization of a nation with dignity in the context of the intellectual life of the nation. National Education aims to develop the potential of students to become human beings who have faith and are devoted to God Almighty, have good character, are healthy, knowledgeable, capable, creative, independent, and become citizens who are democratic and responsible. This is not without foundation but is a manifestation of the implementation of the Minister of Education and Culture Regulation of the Republic of Indonesia Number 23 of 2015 concerning Character. Character education should be a joint movement involving the central government, regional government, community, and / or parents. Based on this, schools are part of the government that seeks to implement regulations as an active role in building better human resources through education.

Kamaruddin (2012) states that character education is an effort in order to build student character to be better because the character and personality of students are very easy to be formed. Etymologically, the character can be interpreted as something that is inherent in nature that influences behavior, character or temperament. Whereas in terminology, the character can be interpreted as the mental, moral or moral nature that characterizes a person or a group. It aims to create the character of students who are perfect, to the point where human beings are realized. However, it can be clarified in an effort to realize spiritual, emotional, intellectual, and aesthetic intelligence.

Character education has a major role to advance the nation's civilization to become a nation that is increasingly leading the way with knowledgeable, insightful and characterless Human Resources. Student character education is very broad because it is related to the development of multi aspects of the potential advantages of the nation. Described in the training material for strengthening learning methodology based on cultural values to shape the competitiveness and character of the nation, the Curriculum Center of the Ministry of National Education (2010) states that: (a) character is essential in the nation and state, the loss of a character will cause the loss of the next generation of the nation, (b) the character plays a role so that the nation is not swayed, (c) the character must be built and formed to become a dignified nation.

Zeidler et al. (2014) believe that the formation of character and character through schools, cannot be done solely through knowledge learning, but is through the cultivation or education of values. In general, studies of values usually cover two main areas, namely: aesthetics and ethics (or morals, morals, character). While ethics refers to the justification of behavior that applies to society, whether sourced from religion, customs, conventions, and so on. These behaviors are moral values or morals about which actions are good and which are bad.

Character education is the process of giving guidance to students to become fully human beings who have a character in the dimensions of heart, mind, body and intention. This refers to the conclusion that students who live in a social environment can influence the formation of their character (Rozali et al., 2020). Schools as one of the environments that shape the character of students are expected to be able to provide good treatment so that good character is formed. Students at the elementary school level are included in the concrete operational stages. This shows that students need to be directly involved in activities in school and the learning process related to the planting of characters to the fullest to form the character of students. In addition, character-based education needs to pay attention to the learning process related to the achievement of character education (Samani & Hariyanto: 2012).

Liu & Littlewood (1997) made efforts to instill positive character for elementary school students and it can be done through local cultural material. In addition to facilitating the delivery of scientific material, the implementation of local culture in the learning process is believed to be a strategic effort in instilling character values and is easy for students to remember. A similar sentiment was also conveyed by Sumarni, et al (2015) that character education based on local culture is needed to develop moral qualities, personalities, and community attitudes which are increasingly eroded by the times. The implementation of local culture-based character education for elementary school students is inseparable from a dynamic, which aims to provide more provision for primary school students in facing life in the community (Henderson & Mapp, 2002). The application of the concept of character education based on local socio-cultural wisdom, stated by Power (1994), consisting of 9 (nine) character pillar education models. Each pillar character theme is set to be applied for 2 to 3 weeks. Each pillar theme consists of various examples of practical activities for educators focused on the method: knowing the good, feeling and loving the good and acting the good.

Aim of any education is to enable every student to comprehend and consolidate one's ability, which is coined as self-actualization (Piragasam, 2018) and the role of teachers makes up to develop students' cognition (Triyono et al., 2020; Kassymova et al., 2020). Assessment of learning outcomes and feedback are central to developing learners' competence (Amri et al., 2020) and confidence in the workplace (Kenzhaliyev et al., 2020). From a psychological perspective for students as well as researchers, it is important to get results of their studying measured in both technical (Volodin et al., 2020; Kenzhaliyev et al., 2020) and social humanitarian (Apendiyev, 2019) sciences. Learners value the assessment that helps them develop themselves, facilitates self-reflection and motivates them to learn more and improve the learning outcomes based on the assessment system.

Assessment of characters in students is not an easy thing. A teacher must be able to choose a source of assessment and media that is appropriate to the level of education remaining to be assessed. The teacher needs to make an assessment of the extent to which the character is embedded in students, as an effort to build student character to be better. However, this is not in line with the assessment process that occurs in the field. Carrying out an assessment, evaluation of processes and learning outcomes is a pedagogical competency that must be implemented by the teacher. Assessment according to the Republic of Indonesia Minister of Education and Culture Regulation Number 23 the Year 2016 is a process of gathering and processing information to measure the achievement of student learning outcomes. Learning outcomes assessment instruments are grouped into two namely test and non-test. Test assessment is done to test students' cognitive abilities. In affective and psychomotor abilities students can use non-test assessment forms (Oviawe, 2020).

Based on the results of interviews conducted by researchers in Bantul District, it was revealed that 69.30% of teachers did not yet have an instrument of character education assessment. This is not in line with the teacher's understanding of the importance of character assessment in students through character education. While in the implementation of the assessment found 73.3% of teachers did not make an assessment of the characters embedded in students. The results of the interview also showed that the unavailability of character education assessment instruments was caused by the teacher having difficulty in making the assessment instruments and only using the existing instruments. Some teachers said the difficulty was due to the lack of examples of character education assessment for elementary school students (Yustina et al., 2020). Interviews were also carried out related to time constraints, so far the obstacles experienced by the teacher besides the difficulty of making instruments namely time. The teacher does not have enough time to make an instrument of character education assessment so that the teacher only observes the attitudes displayed by students during the learning process and outside of learning but is still within the scope of the school.

According to Deswila et al. (2020) social attitudes which are character values in the 2013 curriculum include disciplined, honest, caring, confident, polite and responsible attitude. For elementary school students, the assessment of character education can be done using a non-test instrument through a questionnaire. The questionnaire was presented specifically and then students were asked to respond. McCoach et al. (2013) explain a good questionnaire in the course of making it through the procedure: "In selecting an affective characteristic for measurement, the developer's instrument should carefully consider the theory underlying the construct. Only with a clear conceptual understanding can one proceed to create valid operational definitions (i.e., statements/items) for each affective characteristic".

This definition can be interpreted that in selecting characteristics in the development of instruments need to be careful in considering the selection of theories in a construct. Through good understanding, valid operational definitions can produce for each character to be assessed. This shows that in evaluating character education it should not be arbitrary in making operational definitions

which are then developed into attitude indicators that will be assessed. The teacher certainly needs to understand this as an effort to help recognize the attitudes reflected in students. In addition, the preparation of items needs to be tested for validity and estimating reliability.

Validity is done to ensure that it is feasible to use to measure what should be measured, and reliability estimation is intended that the instrument has a certainty or consistency in measuring student attitudes, in this case, the characters that are embedded in students (Schmidt et al., 2000). The results of interviews conducted by researchers showed that there were no teachers who tested the validity and reliability of the character education assessment instruments for students. Based on this, it can be said that the instruments that have been used by some teachers can be said to be not feasible to measure the characters embedded in students. Instruments that are not feasible to measure the character of students cause the students' personalities to not be described in detail. Based on this, it is necessary to have a proper instrument to measure the characters that are embedded in students in the form of students' social attitudes such as caring, polite, honest, disciplined in detail through local culture in D. I. Yogyakarta. The local culture used in this research is a traditional game that is loved by students, for instance, Gobag Sodor, Plot of Umpet, Engklek, and Dekak-dekak.

RESEARCH METHODS

This research aims at instrument development of character education assessment based on local socio-cultural wisdom for elementary school students. The model used in this study refers to the Plomp model that is integrated with the instrument development steps in Djemari Mardapi's book. The Plomp model development (1997) consists of five phases, namely (1) preliminary investigation phase, (2) design phase, (3) realization/construction phase, (4) test, evaluation, revision phase, and (5) implementation phase. Mardapi (2008) there are nine steps that need to be taken in developing a test of achievement or learning achievement, namely: (1) compiling test specifications, (2) writing test questions, (3) examining test questions, (4) conducting trials tests, (5) analyzing items, (6) improving test s, (7) assembling tests, (8) carrying out tests, (9) interpreting test results.

The development models proposed by the experts have the same basis, although they contain different stages. Thus, the researchers chose to modify two development models, especially the Plomp model which is combined with the steps of developing the Mardapi instrument; it is considered that the development stage was relatively more complete and relatively simple and practical as one of the development models of the assessment instruments. The stages of research and development carried out in this study include 1) analysis of needs and gathering initial information; 2) planning; 3) preparation of instruments; 4) evaluation and revision, and 5) dissemination and implementation. The development model is presented in Figure 1.

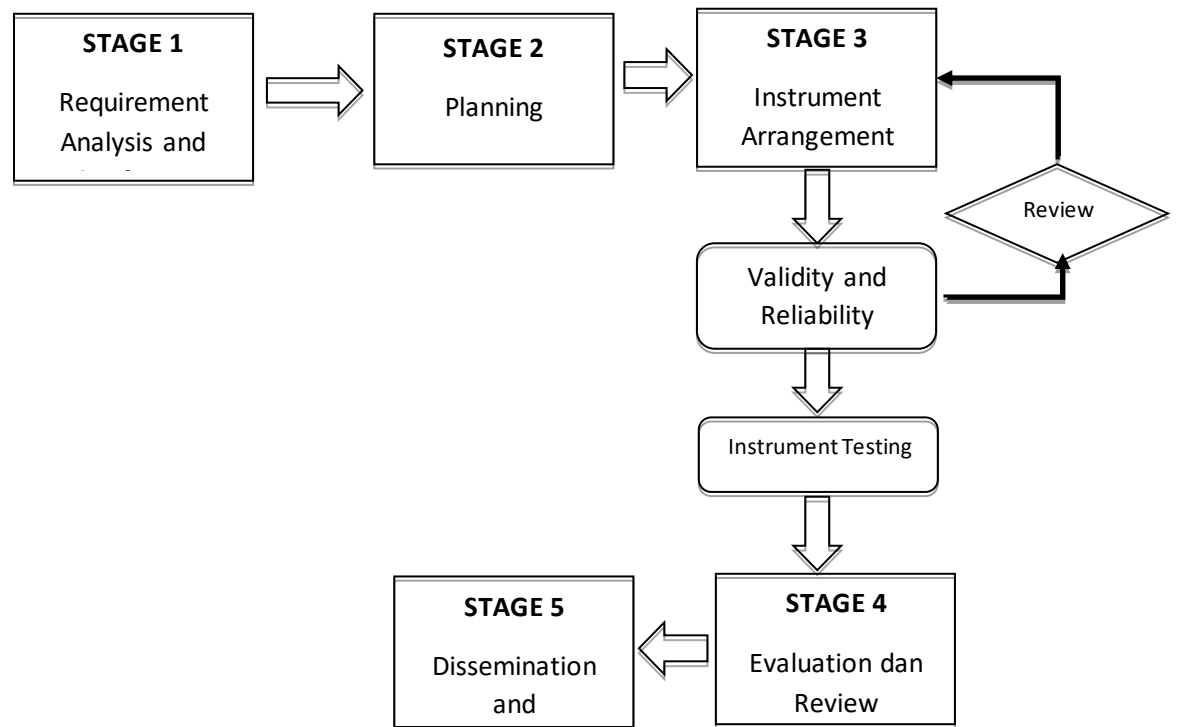

Figure 1. Procedure for developing local culture-based character education assessment instruments for elementary school students

The instrument developed using the Plomp model is an instrument of character education assessment for elementary school students. The type of instrument developed is self-assessment. Students do self-assessment of the attitude of discipline, honesty, caring, and polite. The development of the instrument at an early stage was carried out by analyzing the needs and gathering preliminary information from the four attitudes. Needs analysis and gathering of initial information obtained on each attitude are developed into indicators that can be compiled by researchers with teachers in Focus Group Discussions (FGD).

The results of the FGD were then used to plan to proceed by compiling the instruments in this study. The finished instrument is then tested for its validity and reliability is estimated. Validity is tested in terms of content and contract. The content validity was carried out by experts and was analyzed using Aiken's formula. Retnawati (2015) states that the magnitude of the coefficient of validity that was acceptable and considered feasible was ≥ 0.60 . Prihono (2020) describes Aiken's V formula for content validity, as follows:

$$eV = \frac{\sum (S - c)}{n(c-1)}$$

Information:

eV = rater agreement index

n = number of raters

S = the score set for each rater minus the lowest score in the category used

or $S = r - lo$

lo = lowest validity rating number (in this case = 1)

c = highest validity rating (in this case = 5)

r = number given by an assessor/validator

The construct validity is done by exploratory and confirmatory factor analysis tests. The construct validity is done to show the extent to which the test results are able to reveal a trait or a theoretical construct that will be measured; proof of construct validity is a process that continues in line with the development of the concept being measured. Azwar (2015) said that the exploratory factor analysis was carried out to ascertain whether certain items supported the factors and those factors supported the variables. The exploratory factor analysis criteria fulfilled in this analysis include:

- 1) Keyser Mayer Oikin (KMO) > 0.5;
- 2) Sig. Barlett's Test of Sphericity < 0.05;
- 3) Anti image correlation > 0.5;
- 4) Eigen value on Total Variance Explained > 1.0; and
- 5) The coefficient on the Rotated Component Matrix > 0.4;

The valid instrument is obtained based on the results of the exploratory factor analysis. Next, it is tested further, confirmatory factor analysis. Hendryadi & Suryani (2014) state that the criteria in the CFA analysis, that can determine the suitability of the model with the help of using Lisrel software, are determined as follows:

- 1) Chi-Square with p-value < 0.05;
- 2) Root Mean Square Error of Approximation (RMSEA) ≤ 0.08;
- 3) Goodness of Fit Index (GFI) ≥ 0.90;
- 4) Standardized Root Mean Square Residual (SRMR) ≤ 0.05;
- 5) Adjusted Goodness Fit of Index (AGFI) ≥ 0.90;
- 6) Comparative Fit Index (CFI) ≥ 0.90;
- 7) Incremental for Index (RFI) ≥ 0.90.

In the next stage, the instrument that has been declared valid is estimated to be reliable. The criteria for determining instrument reliability are based on Alpha coefficients > 0.5 (Wagiran, 2015). Mehrens and Irvin (1973) stated that reliability is a degree of consistency between two results of measurements on the same object. The instrument reliability criteria were set by the researcher in accordance with the existing theoretical aims to obtain an accurate and trustworthy instrument.

The trial was conducted on Grade V of elementary school students in the Province of D. I. Yogyakarta. Table 1 presents the list of locations.

Table 1. List of Test Subject Locations

Regency/City	Number of Primary Schools	Number of Respondents/Students
Bantul	5	165
Gunungkidul	5	152
Kulon Progo	5	155
Sleman	5	164

Yogyakarta	4	138
Total	24	774

The trial was conducted in elementary schools using the 2013 Curriculum. The determination of the test subjects in this study used non-probability sampling with a purposive sampling technique. Wagiran (2015) explains that the purposive sampling technique is chosen based on specific goals and purposes. The purpose of choosing the test subjects in this study is a school that has implemented the 2013 Curriculum as a whole. School characteristics that are consistent with this study are found in 24 elementary schools. These schools by the District/City Education Agency in the Province of D. I. Yogyakarta were designated as pilot schools for the implementation of the 2013 Curriculum. So that in implementing the curriculum, teachers who would be invited to the FGD process did not experience difficulties.

RESEARCH RESULTS AND DISCUSSION

It is an instrument development research used for the assessment of character education based on local socio-cultural wisdom for elementary school students. Therefore, the validity and reliability estimation tests are performed in the process of instrument preparation in order to meet the suitability of an instrument. Validity test is done through content and constructs validity tests. Content validity is done through expert agreement (expert judgment). The instrument of character education assessment based on local socio-cultural wisdom for elementary school students consisted of 15 statement items with a Likert scale. The instrument assessment was carried out by three experts and the value of the experts was used to calculate the magnitude coefficient of Aiken's content V. The results of the analysis of the content validity of the character education assessment instrument based on local socio-cultural wisdom for elementary school students are presented in

Table 2. Aiken's V Score Instrument of Local Culture Based Character Education

Item Number	1	2	3	4	5	6	7	8	9	10	11	12	13	14	15
Aiken's V	0.70	0.64	0.61	0.63	0.64	0.65	0.67	0.72	0.64	0.68	0.65	0.68	0.61	0.66	0.64

The content validity test results showed that the Aiken's index for each item ≥ 0.60 so that the coefficient of validity was accepted and considered to be feasible

and it could be said that the instrument was valid in content (Retnawati, 2015). After the instrument has been considered content appropriate, a construct validity test is carried out with exploratory and confirmatory factor analysis. Exploratory factor analysis results show that the Kaiser-Meyer-Olkin Measure of Sampling Adequacy (KMO) value is 0.926 (> 0.5) and the Sig. Bartlett's Test of Sphericity of 0,000 (< 0.05) is presented in Table 3. Overall the results of exploratory factor analysis are indicated in Table 4.

Table 3. KMO and Bartlett's Test

KMO and Bartlett's Test		
Kaiser-Meyer-Olkin Measure of Sampling Adequacy.		,926
Bartlett's Test of Sphericity	Approx. Chi-Square	3124,879
	df	105
	Sig.	,000

Table 4. Results of Exploratory Factor Analysis

Kriteria EFA	Criteria	Score
Nilai Keyser Mayer Oikin (KMO)	> 0.5	0.926
Sig. Barlett's Test of Sphericity	< 0.05	0.000
Korelasi anti image	> 0.5	0.930; 0.939; 0.908; 0.925; 0.942; 0.936; 0.921; 0.914; 0.913; 0.928; 0.951; 0.937; 0.908; 0.913; 0.918
Eigen value	> 1.0	5.343; 1, 269
Rotated Component Matrix	> 0.4	0.550; 0.491; 0.688; 0.730; 0.450; 0.563; 0.424; 0.495; 0.694; 0.751; 0.543; 0.492; 0.702; 0.709; 0.664

All items on the instrument meet the criteria, namely the value of each item on the loading factor > 0.4 . So all items are declared valid and formed into 2 components. Researchers conducted the further analysis using Confirmatory Factor Analysis (CFA) based on the clusters obtained through exploratory factor analysis (EFA). CFA is carried out using the help of Lisrel 8.54 software. The results of the CFA include Basic Model Standardization Solution and it can be seen in Figure 2.

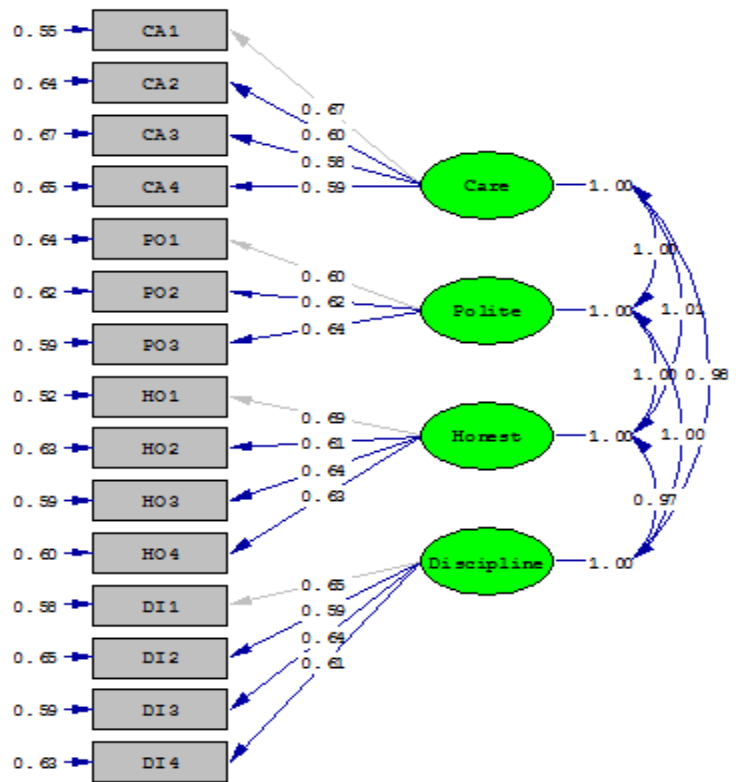

Chi-Square=111.01, df=84, P-value=0.02588, RMSEA=0.020

Figure 2. Basic Model Standarization Solution

It can be seen from the standardization solution based on the model image; it shows that the p-value of 0.02588 and RSMEA which is close to 0 is 0.020, so it can be said that the factor model used is good or there is a model fit. In addition to

the standardized solution, it can also be seen through the t value shown in Figure .

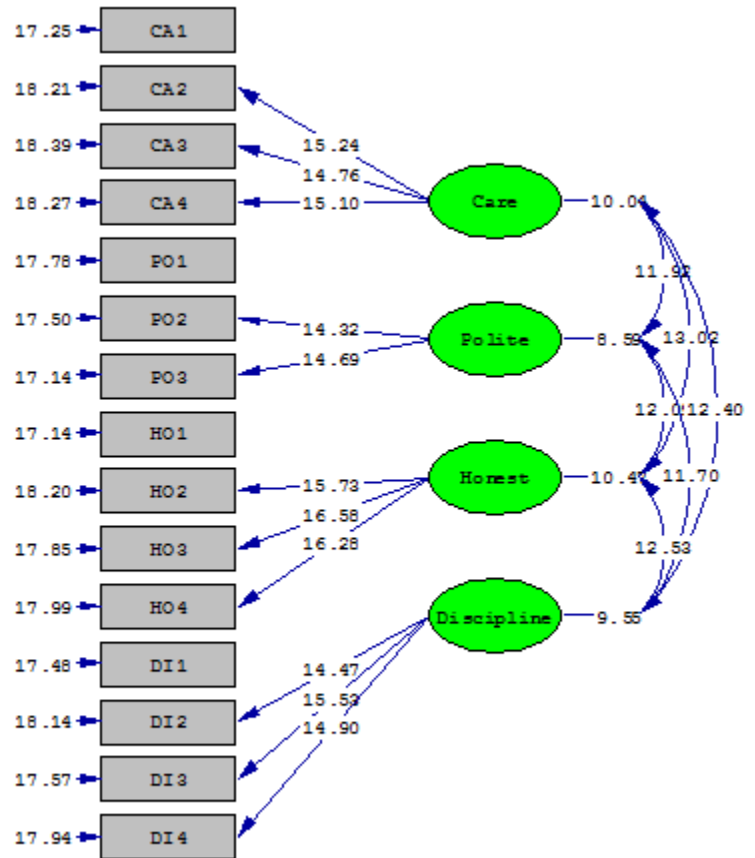

Chi-Square=111.01, df=84, P-value=0.02588, RMSEA=0.020

Figure 3. Basic Model T- Value

Table 5. Confirmatory Factor Analysis Results

Criteria CFA	Criteria	Score	Information
<i>Chi Kuadrat (P-value)</i>	< 0.05	0.024	Received
RSMEA	≤ 0.08	0.020	Received
GFI	≥ 0.90	0.98	Received
SRMR	≤ 0.05	0.021	Received
AGFI	≥ 0.90	0.97	Received
CFI	≥ 0.90	0.99	Received
RFI	≥ 0.90	0.97	Received

The reliability of the character education assessment instrument based on local socio-cultural wisdom for elementary school students was estimated reliability using the Cronbach’s Alpha coefficient. Brown (2002) suggests that Cronbach alpha can provide estimates of internal consistency in testing so that it shows the consistency of instruments over time. The

results of the reliability estimation based on the Cronbach's Alpha coefficient are presented in Table 6.

Table 6. Reliability Results Based on Cronbach's Alpha

Reliability Statistics	
Cronbach's Alpha	N of Items
.869	15

Estimated reliability using the Cronbach's Alpha method, then a reliability t count of 0.869 was obtained. This shows that from the 15 item statements tested have reliable criteria because $t_{arithmic} > \text{significance level } \alpha (0.05)$ with $n = 15$. Fifteen items that have been tested have reliable criteria and are categorized as very high reliability because they have a reliability value > 0.80 (Wagiran, 2015; Retnawati: 2015). Based on Table 6, it can be concluded that all the instruments used in this study were declared reliable. Thus, the instrument can be used and trusted to re-measure the same object because it has high reliability and feasibility or at least has a reliability coefficient value > 0.7 . This shows that the indicators used already have adequate internal consistency reliability, meticulous in measuring character values embedded in students.

The preparation of the instrument is carried out through several stages, namely: 1) analysis of needs and preliminary information gathering; 2) planning; 3) preparation of instruments; 4) evaluation and revision, and 5) dissemination and implementation. In addition, so that the instrument of character education assessment can be used properly, testing the validity and reliability is carried out. This is in accordance with the opinion of Wilkerson & Lang (2007) who stated that the standard of teacher competency measurement is done by looking at the standard of completeness of the test related to the validity and reliability of a test set.

The results of content validity analysis with Aiken's V for each item are mostly included in the category of high validity with a coefficient ≥ 0.60 . Furthermore, the construct validity is tested for all items on the instrument. Testing the construct validity using factor analysis (confirmatory factor analysis) aims to confirm a measurement theory in order to compare theoretical with empirical results. In addition, construct validity is used to state the criteria that can determine the suitability of the model presented. This is in line with Saptono's statement (2017) which states that the measurement model in confirmatory factor analysis is based on the priority of fit criteria. This is to test the suitability of theoretical models with empirical data. The criteria to be considered in the factor analysis of local culture-based character education assessment instruments are for Standardized Loading Factor (SLF) values > 0.5 , factor loadings at $T\text{-value} > 0.4$, $p\text{-value}$ more than $\alpha (> 0.05)$ and RMSEA is close to 0.

The instrument reliability estimation shows that the coefficient is > 0.80 . So that the instrument of character education based on local culture is said to be reliable with a very high category. This shows that the instrument has stable measurement results. According to the obtained description, it can be concluded that the assessment instrument of local culture-based character education assessment has been prepared by the rules and provisions of the preparation of the instrument. In addition, researchers have proven the validity and reliability estimation of the instrument. The criteria for validity and reliability in the preparation of the instrument have been met. So the local culture-based character education assessment instrument is feasible to be used in measuring character values in elementary school students.

CONCLUSION

To sum up the results of this study, it can be concluded that the assessment instrument to measure character education based on local socio-cultural wisdom for students of elementary schools in grade V has been declared feasible and fulfilled the requirements namely the fulfilment of the validity and reliability criteria of an instrument. Fulfilled validity and reliability of an instrument prove that the used instrument is appropriate to measure something that should be measured, namely the instrument can measure character education based on local socio-cultural wisdom. Suggestions and recommendations from this research, including 1) this instrument can be used to find out the extent of character education embedded in students, 2) for educators who will develop instruments of character assessment based on local social and cultural wisdom for students at other levels are expected to follow the steps provided in this study.

REFERENCE

- Amri A. N., Azman M. A., Shah A., Kassymova G. K. (2020), Integrated Special Education Program Students Involvement of the Woodworking Training Skills by Using Teaching Aid. *Opción*, Año 36, Especial No.26 (2020): 1964-1986
- Apendiyev, T.A., Abdukadyrov, N.M., Kubeyev, R.D. (2019), History of German diaspora in Kazakhstan in the context of migration system. *Bulletin of the Georgian National Academy of Sciences*, Vol. 13, Issue 4, 2019, p. 127-134
- Azwar, S. (2015). *Reliabilitas dan Validitas Edisi 4*. Yogyakarta: Pustaka Belajar.
- Brown, J. D. (2002). The Cronbach alpha reliability estimate. *JALT Testing & Evaluation SIG Newsletter*, 6(1).
- Deswila, N., Kustati, M., Besral, B., & Sukandi, S. S. (2020). Content and Language Integrated Learning (CLIL) Approach across Curriculum in Science Classrooms: Are the English Language Use and Learning Reveal? 1(1), p.15-21. <https://doi.org/10.46843/jiecr.v1i1.4>

- Henderson, A. T., & Mapp, K. L. (2002). *A New Wave of Evidence: The Impact of School, Family, and Community Connections on Student Achievement*. Annual Synthesis, 2002.
- Hendryadi, & Suryani. (2014). Structural equation modeling dengan lisrel 8.80 pedoman untuk pemula. Yogyakarta: Kaukaba Dipantara.
- Kamaruddin, S. A. (2012). Character education and students social behavior. *Journal of Education and Learning*, 6(4), 223-230.
- Kassymova G., Bekalaeva A., Yershmanova D., Flindt N., Gadirova T. and Duisenbayeva Sh. (2020). E-Learning Environments and Their Connection to the Human Brain. *International Journal of Advanced Science and Technology*, 29(9s), 947 - 954. Retrieved from <http://sersec.org/journals/index.php/IJAST/article/view/13359>
- Kenzhaliyev O.B., Kassymova G.K., Triyono B.M., Azman M.N.A., Ilmaliyev Zh.B. (2020), Case Study: E-Learning Via EF English Live as A Means to Improve Competitiveness Among University Staff. In *The Framework of Portfolio Project Management*. *Journal of Talent Development and Excellence*. Vol. 12 No. 2s., p. 3705-3720. Retrieved from: <http://www.iratde.com/index.php/jtde/article/view/1277/976>
- Kenzhaliyev, B.K., Trebukhov, S.A., Nitsenko, A.V., Burabayeva, N.M. (2020). Extraction of selenium from the dusts of bag dust filters of the kaldo furnace, *International Journal of Mechanical and Production Engineering Research and Development*, 10(3), p. 547-552. <https://doi.org/10.24247/ijmperdjun202050>
- Liu, N. F., & Littlewood, W. (1997). Why do many students appear reluctant to participate in classroom learning discourse?. *System*, 25(3), 371-384. [https://doi.org/10.1016/s0346-251x\(97\)00029-8](https://doi.org/10.1016/s0346-251x(97)00029-8)
- Mardapi, D. (2008). *Teknik penyusunan instrumen tes dan nontes*. Yogyakarta: Mitra Cendekia.
- McCoach, D. B., Gable, R. K., & Madura, J. P. (2013). *Instrument development in the affective domain*. New York: Springer New York.
- Mehrens, W. A. L., & Irvin, J. (1973). *Measurement And Evaluation In Education And Psychology*/William A. Mehrens And Irvin J. Lehmann (No. LB1051. M43 1991).
- Oviawe, J. I. (2020). Technical Education Lecturers' Knowledge of Students' Engagement in Application of Interactive Instructional Strategies. *Journal of Technology and Humanities*. 1(1), 1 – 10.
- Piragasam, G. A. (2018). Self-actualization of the gifted and talented: a measurement using the brief index of self-actualization. *Muallim Journal of Social Sciences and Humanities*, 2(2), 107-118. Retrieved from <https://www.mjsshonline.com/index.php/journal/article/view/23>
- Plomp, T. (1997). *Educational and training system design*. Enschede, The Netherlands: Univercity of Twente.

- Power, F. C. (1994). Piaget on the moral development of forgiveness: Identity or reciprocity. *Human Development*, 37, 81-85.
- Prihono, E. W. (2020). Validitas Instrumen Kompetensi Profesional pada Penilaian Prestasi Kerja Guru. *Ekspose: Jurnal Penelitian Hukum dan Pendidikan*, 18(2), 897-910. <https://doi.org/10.30863/ekspose.v18i2.529>
- Retnawati, H. (2015). *Validitas dan Reliabilitas Karakteristik Butir*. Yogyakarta: Parama Publishing.
- Rozali, M. Z., Puteh, S., Ismail, A., Marian, M. F., & Firdaus, M. (2020). Factor of Active Participation Engineering and Technical Student-Athletes in Co-Curricular Activities (Sport). *Journal of Technology and Humanities*. 1(1), 34 – 38.
- Samani, H., & Hariyanto. (2012). *Pendidikan karakter*. Bandung: PT Remaja Rosdakarya.
- Saptono, A. (2017). Development Instruments Through Confirmatory Factor Analysis (CFA) in Appropriate Intensity Assessment. *Dinamika Pendidikan*, 12(1), 13-19. <https://doi.org/10.15294/dp.v12i1.10578>
- Schmidt, F. L., Viswesvaran, C., & Ones, D. S. (2000). Reliability is not validity and validity is not reliability. *Personnel Psychology*, 53(4), 901-912. <https://doi.org/10.1111/j.1744-6570.2000.tb02422.x>
- Sumarni, S. M., Dardiri, A., & Zuchdi, D. (2015). The Development of Character Education Model Based on Strengthening Social Capital for Students of State Islamic University (UIN) Sunan Kalijaga. *Journal of Education and Practice*, 6(1), 13-22.
- Triyono, B.M., Mohib, N., Kassymova, G.K., Pratama, G.N.I.P., Adinda D., Arpentieva, M.R. (2020). The Profile Improvement of Vocational School Teachers' Competencies. *Vysshee obrazovanie v Rossii = Higher Education in Russia*. Vol. 29, no. 2, pp. 151-158. <https://doi.org/10.31992/0869-3617-2020-29-2-151-158>
- Volodin V. N., Tuleushev Y. Zh., Kenzhaliyev B. K., Trebukhov S. A. (2020). Thermal degradation of hard alloys of the niobiumcadmium system at low pressure. *Kompleksnoe Ispol'zovanie Mineral'nogo syr'â = Complex Use of Mineral Resources = Mineraldik Shikisattardy Keshendi Paidalanu*, 1(312), 41–47. <https://doi.org/10.31643/2020/6445.05>
- Wagiran. (2015). *Metodologi penelitian pendidikan*. Yogyakarta: Budi Utama.
- Wilkerson, J. R., & Lang W. S., (2007). *Assessing Teacher Competency: Five Standards-Based Steps to Valid Measurement using the CAATS Model*. California. Corwin Press. *Applied Measurement in Education*, 22(1), 104–107. <https://doi.org/10.1080/08957340802558417>
- Yustina, Y., Halim, L., & Mahadi, I. (2020). The Effect of 'Fish Diversity' Book in Kampar District on the Learning Motivation and

Obstacles of Kampar High School Students through Online Learning during the COVID-19 Period. *Journal of Innovation in Educational and Cultural Research*. 1(1), p. 7-14. <https://doi.org/10.46843/jiecr.v1i1.2>

Zeidler, D. L., Berkowitz, M. W., & Bennett, K. (2014). Thinking (scientifically) responsibly: The cultivation of character in a global science education community. In *Assessing schools for generation R (Responsibility)*, pp. 83-99. Springer, Dordrecht. https://doi.org/10.1007/978-94-007-2748-9_7